

LaserPAD™

Laser Power Analysis Display System

FEATURES

- Complete PC and handheld PDA based Laser Power Measurement
- Up to 4 measurement channels standard for PC's (more for OEM configurations)
- Choice of over 25 SmartSensors™ for wavelengths from 190 nm to 10.6 μm
- CW power measurement from 10 nW to 5 kW
- Full Statistical and Power Trend Analysis
- NIST Traceable Calibration, ISO and CE Compliant



LaserPAD

OVERVIEW

The innovative LaserPAD Laser Power Analysis Display system is a new approach to computer based Laser Power Measurement and Analysis using Coherent's SmartSensor laser power detector technology. It combines the convenience, value and flexibility of using a variety of computer platforms with a choice of over 25 NIST traceably calibrated thermal and semiconductor SmartSensors to provide accurate laser, diode and fiber optic power measurements from 10 nW to 5 kW. LaserPAD software application packages make single or multichannel power monitoring applications easy with a complete set of statistical analysis, graphics display and data storage functions.

The LaserPAD system can also be custom configured with the OEM Tools software package for many user specific laser power measurement applications. With up to 127 input channels possible, the LaserPAD system and OEM Tools software can provide scalable integrated built-in testing or multiple work station laser process monitoring for feedback control.

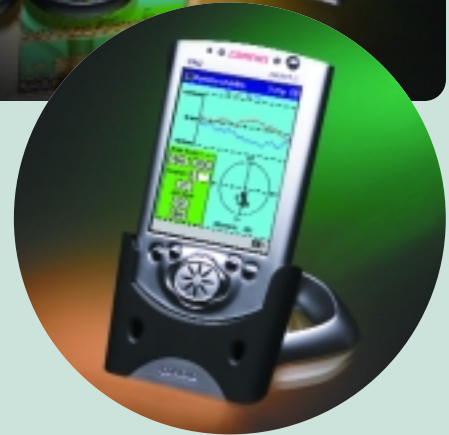

The LaserPAD system consists of 3 different software packages and the SmartSensor Interface Module.



SmartSensor Interface Module

The LaserPAD system utilizes the new Coherent SmartSensor Interface Module (SSIM) to connect the full line of thermal and semiconductor SmartSensors to a computer system through its RS-232 or USB serial interface. The microprocessor controlled SSIM includes a complete set of interface commands to provide the connected computer system with full remote control and NIST calibrated power readings from the SmartSensor for analysis and display. The SIMM also includes rechargeable Ni-Cd batteries for up to 12 hours of continuous portable operation.



LaserPAD System Software Applications

Along with the SmartSensor Interface Module, three software packages are provided with the LaserPAD system. The **LaserPAD PC application software** package provides up to 4 channel laser power measurement and analysis for PC based Windows computers. The **LaserPAD PDA application** provides single channel analysis on Pocket PC PDA (Personal Digital Assistant) devices. The **OEM Tools software package** provides assistance in user development of custom laser power measurement applications with a suite of .ocx and .dll tools and example application programs.

LaserPAD PC Software Application

The standard LaserPAD PC software is a full Windows® based 4-channel power measurement application package for PC computers that includes complete data logging, statistical and trending analysis along with beam position displays (for thermal SmartSensors).



Beam Position

When using thermopile SmartSensors, the LaserPAD PC application software displays absolute or relative beam alignment and position stability information for each channel simultaneously. Beam position can be tracked and displayed for each channel on a polar plot and strip chart for a selected period of time. For beam alignment, the sensor center (target) can be zoomed up to 32X with resolution to 0.01 mm.

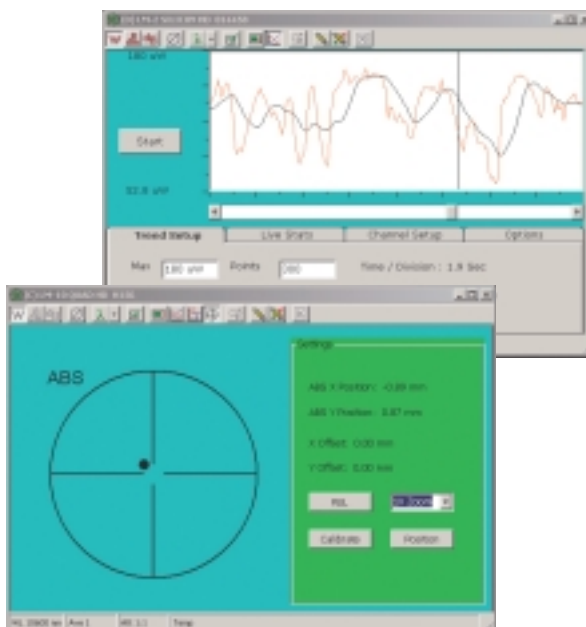

Additional features include:

- Selectable averaging of 1 to 200 readings for noisy sources.
- Programmable attenuation factors from 100,000:1 to 0.01:1 (for attenuators, beam splitters, etc.).
- Offset selection for subtraction of background noise.
- Selection of measurement wavelength.
- Unlimited data storage to spread sheet files.
- Selectable measurement limits and alarms.
- Displayed Power units in Watts, dB or dBm.
- Multi-channel math functions (ratios, difference, etc.).

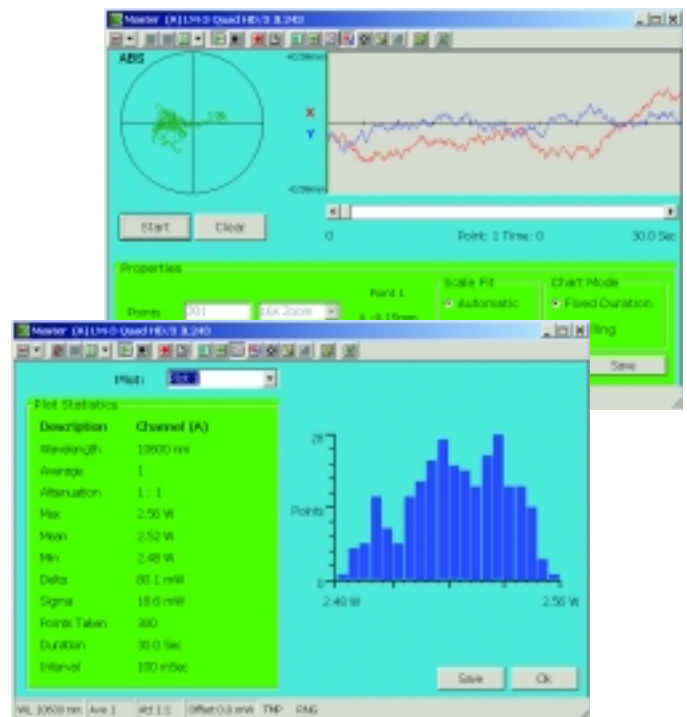

Statistical and Trend Analysis

The LaserPAD PC can perform complete statistical and trend analysis for power stability and drift for each channel simultaneously. Measurements can be recorded and analyzed over a selected period of time for display on a strip chart or histogram plot for each channel.

Math Functions

When multiple channel power measurements are being made, the LaserPAD PC provides math functions to perform addition, subtraction, division or multiplication operations between the measurement channels. The user can input custom mathematical formulas using these operations.



Data Logging and Recording

The LaserPAD PC data logging functions collect user specified Power and Position data at selected intervals and durations. Pass/Fail limits can be set to ignore data falling outside of desired ranges. The data log files contain all test information (data, time, detector and settings), power and position data and is formatted for easy spreadsheet importing and analysis. Data can also be recorded in a real time (10Hz) mode and played back at a later date to reproduce the displayed results as if the data were being seen for the first time from an active detector.

Minimum PC Requirements

- MS Windows® 98, ME, 2000 or XP
- 1 USB or RS-232 serial port
- PC with 586 (Pentium II) 233 MHz processor or better
- 64 Mb of RAM (128 Mb recommended)
- 30 Mb free Hard Disk Space
- SVGA graphics card and display (800 x 600 minimum)
- Serial communication port (for remote control operation)

Flexible and Convenient Laser Power Analysis System

This diagram shows the many possible configurations available with the LaserPAD Laser Power Analysis System. By using SmartSensors with up to four SmartSensor Interface Modules (127 for OEM applications), and the LaserPAD software applications packages, single or multichannel laser power measurement applications can be easily made on a variety of computer platforms.

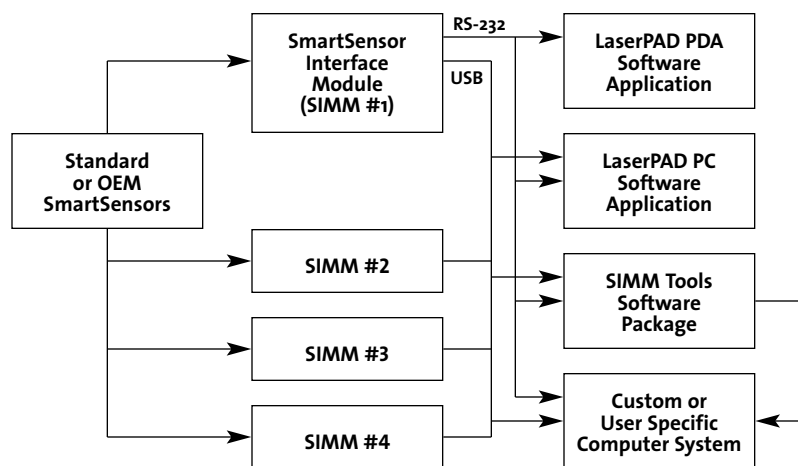

SmartSensors for LaserPAD Systems

All Sensor Heads feature EEPROM-based SmartSensors technology. Detector ID, range, alarm parameters, NIST Traceable calibration dates and serial number are automatically loaded when SmartSensors are used with the LaserPAD system.

Coherent offers over 25 standard SmartSensors for power measurement from 10.0 nW to 5.0 kW and wavelengths from 190 nm to 10.6 μm . A large selection of custom and OEM sensors are also available.

LaserPAD PDA Software Application

The LaserPAD PDA software is a full menu driven power measurement application package for Pocket PC PDA devices that includes complete statistical and trending analysis along with beam position displays for thermal SmartSensors.



Statistics

The LaserPAD PDA can perform complete statistical and power trend analysis for stability and drift measurements. From 40 to 2000 data points can be recorded and analyzed over a selected period of time for display on a strip chart or histogram plot.

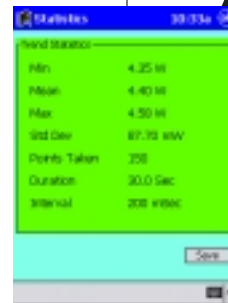

Beam Position

When using thermopile SmartSensors, the LaserPAD PDA applications software displays absolute or relative beam alignment and position stability information. Beam position can be tracked and displayed on a polar plot and strip chart for a selected period of time. For beam alignment, the sensor center (target) can be zoomed up to 32X with resolution to 0.01 mm.

Additional features include:

- *Selectable averaging of 1 to 20 readings for noisy sources.*
- *Offset selection for subtraction of background noise.*
- *Programmable attenuation factors from 100,000:1 to 0.01:1 (for attenuators, beam splitters, etc.).*
- *Selection of measurement wavelength.*
- *Data storage to spread sheet files.*
- *Selectable measurement limits and alarms.*
- *Analog tuning bar or simulated needle.*
- *Displayed Power units in Watts, dB or dBm.*

Current PDA Requirements

- Pocket PC
- Windows CE VER 3.0
- RS-232 Interface
- Current compatible PDAs:
 - Compaq iPAQ
 - Acer
 - HP Jornada
 - Symbol
 - Casio Cassiopeia
 - Audiovox
 - Toshiba

PDA Compatibility

The LaserPAD PDA applications software is currently compatible with most handheld Pocket PC devices utilizing Windows CE VER 3.0 operating systems and an RS-232 interface. Coherent is continuously updating the software to support other devices as well as newly released PDA devices. For the latest list of compatible devices, please call your local Coherent sales representative.

LaserPAD Laser Power Analysis Display System



SmartSensor Interface Module Dimensions

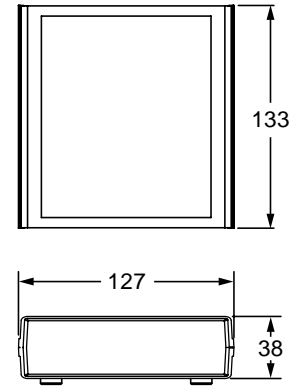

Dimensions are in mm

		SmartSensor Interface Module
Specifications	Accuracy	Display: $\pm 1\%$ of reading ± 2 LSD. System: sum of display and sensor accuracies.
	CW Sample Rate	10 Hz max.
	Ranges	Microprocessor controlled. Ranges determined by EEPROM in SmartSensor heads.
	Communication	USB and RS-232 Communication between Host Computer and SmartSensor Interface Module. ¹
	Memory	The SSIM has the capability to buffer multiple commands to process in a serial order. ²
	Operating Temperature	5°C to 40°C
	Safety Features	Sensor over-temperature, alignment and over-range events.
	Size (LxWxH)	133x127x38 mm
	Weight	400 g with batteries.
	AC Wall Plug Input Requirements	100-240V, ~0.2 A, 50-60 Hz
6V Internal Rechargeable Battery Pack	Recharges automatically during AC operation. Battery life: 12 hours typical. Complete recharge cycle is 14 hours.	

¹ USB Protocol supports up to 127 USB devices.

² Data streaming occurs at a rate of 10 Hz, commands may be processed at a slower rate, based on the host system and the protocol required to process the commands.

		Description
Part Number	1008557	LaserPAD Laser Power Analysis Display System*

* Includes: LaserPAD PDA, LaserPAD PC and OEM Tools Software Application along with a SmartSensor Interface Module, 3.0 M USB cable and manual (see photo at top of page).



COHERENT, INC.

2303 Lindbergh Street
Auburn, CA 95602
Phone: 1-800-343-4912
1-530-889-5365
Fax: 1-530-889-5366

Web: www.Coherentinc.com

LOCAL OFFICES

UK 0800 515801
+44 (0) 1353 658848
Germany +49-6071-968-0
France +33-1-60 19 40 40
Japan +81 (0) 3 5635 8680
Italy +39 (02) 34 530 214

Coherent follows a policy of continuous product improvement. Specifications are subject to change without notice.

For full details on warranty coverage, please refer to the Service and Support section at www.Coherentinc.com, or contact your local Sales or Service Representative.